

MODEL 6700

Downflow Brining

Service Manual



IMPORTANT: Fill in pertinent information on page 2 for future reference.

MODEL 6700 Downflow

Job Specification Sheet

Job Number _____

Model Number _____

Water Test _____

Capacity Of Unit _____ Max. _____ Per Regeneration

Mineral Tank Size: Diameter _____ Height _____

Under Bedding _____ Amount _____

Type of Media _____ Cubic Feet _____

Brine Tank Size _____

Salt Setting Per Regeneration _____

Valve Programming

Water Hardness _____

System Capacity _____

Regeneration Time _____

Regeneration Cycle Step #1 _____

Regeneration Cycle Step #2 _____

Regeneration Cycle Step #3 _____

Regeneration Cycle Step #4 _____

Regeneration Cycle Step #5 _____

Notes:

MODEL 6700 Downflow

General Residential Installation Check List

WATER PRESSURE: A minimum of 25 pounds of water pressure is required for regeneration valve to operate effectively.

ELECTRICAL FACILITIES: An uninterrupted alternating current (A/C) supply is required. Please make sure your voltage supply is compatible with your unit before installation.

EXISTING PLUMBING: Condition of existing plumbing should be free from lime and iron buildup. Piping that is built up heavily with lime and/or iron should be replaced. If piping is clogged with iron, a separate iron filter unit should be installed ahead of the water softener.

LOCATION OF SOFTENER AND DRAIN: The softener should be located close to a clean working drain and connected according to local plumbing codes.

BY-PASS VALVES: Always provide for the installation of a by-pass valve if unit is not equipped with one.

CAUTION: Water pressure is not to exceed 120 p.s.i., water temperature is not to exceed 110°F, and the unit cannot be subjected to freezing conditions.

Installation and Start-up Procedures

1. Place the softener tank where you want to install the unit, making sure the tanks are level and on a firm base.
2. During cold weather it is recommended that the installer warm the valve up to room temperature before operating.
3. All plumbing should be done in accordance with local plumbing codes. The pipe size for the drain should be a minimum of 1/2". Backwash flow rates in excess of 7 gpm or length in excess of 20' require 3/4" drain line.
4. The 1" distributor tube (1.050 O.D.) should be cut flush with top of each tank. Note: Only use silicone lubricant.
5. Lubricate the distributor O-ring seal and tank O-ring seal. Place the main control valve on tank.
6. Solder joints near the drain must be done prior to connecting the Drain Line Flow Control fitting (DLFC). Leave at least 6" between the DLFC and solder joints when soldering pipes that are connected on the DLFC. Failure to do this could cause interior damage to DLFC.
7. Teflon tape is the only sealant to be used on the drain fitting.
8. Make sure that the floor is clean beneath the salt storage tank and that it is level.
9. Place approximately 1" of water above the grid plate. If a grid is not utilized, fill to the top of the air check in the salt tank. Do not add salt to the brine tank at this time.
10. On units with a by-pass, place in by-pass position. Turn on the main water supply. Open a cold soft water tap nearby and let run a few minutes or until the system is free from foreign material (usually solder) that may have resulted from the installation. Once clean, close the water tap.
11. Place the by-pass in service position and let water flow into the mineral tank. When water flow stops, slowly open a cold water tap nearby and let run until the air is purged from the unit.
12. Plug the valve into an approved power source. Once the valve is powered it will drive to the Service Position.

MODEL 6700 Downflow

Installation and Start-up Procedures (Cont'd.)

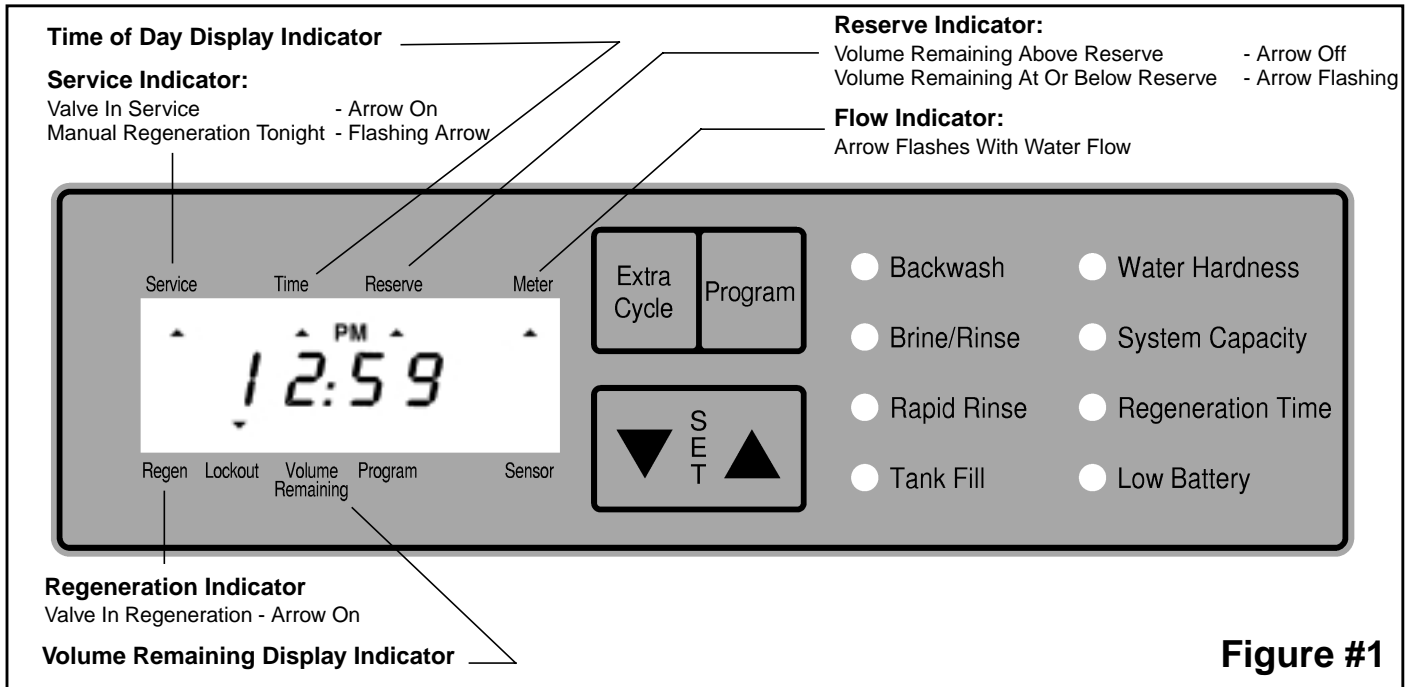

Figure #1

13. Once the valve has reached Service position normal operation is resumed. In normal operation the Time Of Day, and if flow meter equipped, Volume Remaining Displays alternate being viewed. Set the Time Of Day Display by depressing the Up or Down Set Button, to the correct time. (See Fig. 1) Note: Time Of Day must be set correctly to either A.M. or P.M.

For Example:

12:59 A.M.

(Valve in Service)



14. **Flow Meter Equipped Valve Only:** The Volume Remaining Display is the volume of water (in gallons) remaining prior to regeneration, including any reserve capacity. Without any water usage the Meter Arrow should be either off or on but not changing. Open a soft water tap. The Meter Arrow should begin flashing at a rate that varies with flow rate. Close the tap after 3 - 5 gallons of water flow.

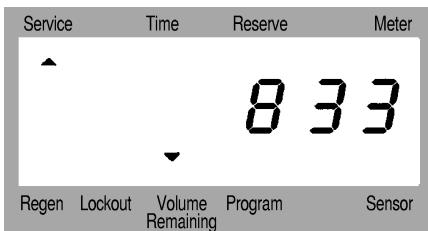

For Example:

833 Gallons Of Water Remaining

(Valve in Service)

(No water flow)

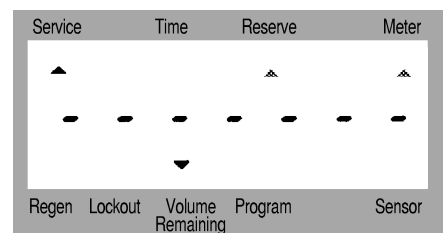

For Example:

0 Gallons Of Water Remaining

(Valve in Service)

(Water flowing, Meter Arrow flashing)

(Volume is below reserve capacity)

(Reserve Arrow flashing)

MODEL 6700 Downflow

Installation and Start-up Procedures (Cont'd.)

15. Manually initiate a regeneration cycle and allow water to run to drain for 3 to 4 minutes. Next, manually step the valve through a regeneration cycle checking valve operation in each step.

A. Initiating Regeneration (Depending on the timer regeneration type you have one or two (2) Options):

1. **Press and Release the Extra Cycle Button.** With Immediate Regeneration Timers the control will go into regeneration immediately. With Delayed Regeneration Timers the Service Arrow will begin to flash immediately and a regeneration will occur at the preset regeneration time (i.e. 2:00 a.m.)
2. **Press and Hold for 5 seconds the Extra Cycle Button.** The control will go into regeneration immediately.

B. Control Operation During Regeneration:

1. During regeneration the control will display the regeneration step number the valve is advancing to, or has reached, and the time remaining in that step.

For Example:

(Valve is advancing to Regeneration Step #1)
(#1 flashing)
(Regeneration arrow on)

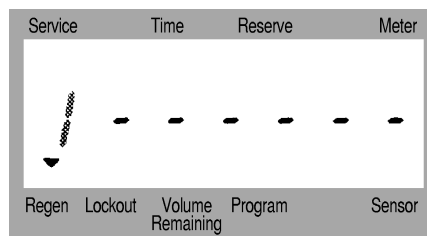

Backwash

2. When the first cycle step is reached, a red LED will turn on to indicate the current regeneration cycle step.

For Example:

(Regeneration Step #1 has been reached)
(10.0 minutes remain in Step #1)

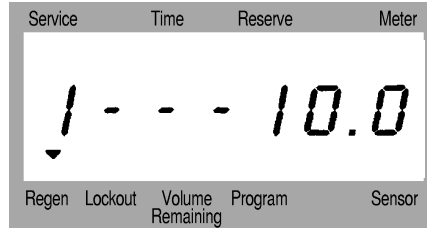

Backwash

3. Pushing the Extra Cycle Button during a regeneration step will immediately advance the valve to the next regeneration step position.
 4. Pushing the Up or Down Set Button during a regeneration step will adjust the time remaining in that current regeneration step. Programmed Regeneration Steps **will not** be changed.
 5. Once all regeneration cycle steps have been completed the valve will return to service and resume normal operation.
16. Add water to the brine tank to the top of the air check. Manually step the valve to the Brine Draw position (see Step #14) and allow the valve to draw water from the brine tank until it stops. Note: The air check will check at approximately the midpoint of the screened intake area.
17. Manually step the valve to the brine refill position and allow the valve to return to service automatically.
18. Make sure the brine refill time (salt dosage) is set as recommended by the manufacturer.
19. With the valve in service, check that there is about 1" of water above the grid in the brine tank, if used.
20. Fill the brine tank with salt.
21. A **9V Alkaline Battery** is recommended to be installed at all times for proper valve operation. The control will indicate when the battery needs to be replaced by turning on the Low Battery LED.

MODEL 6700 Downflow

Control Operation

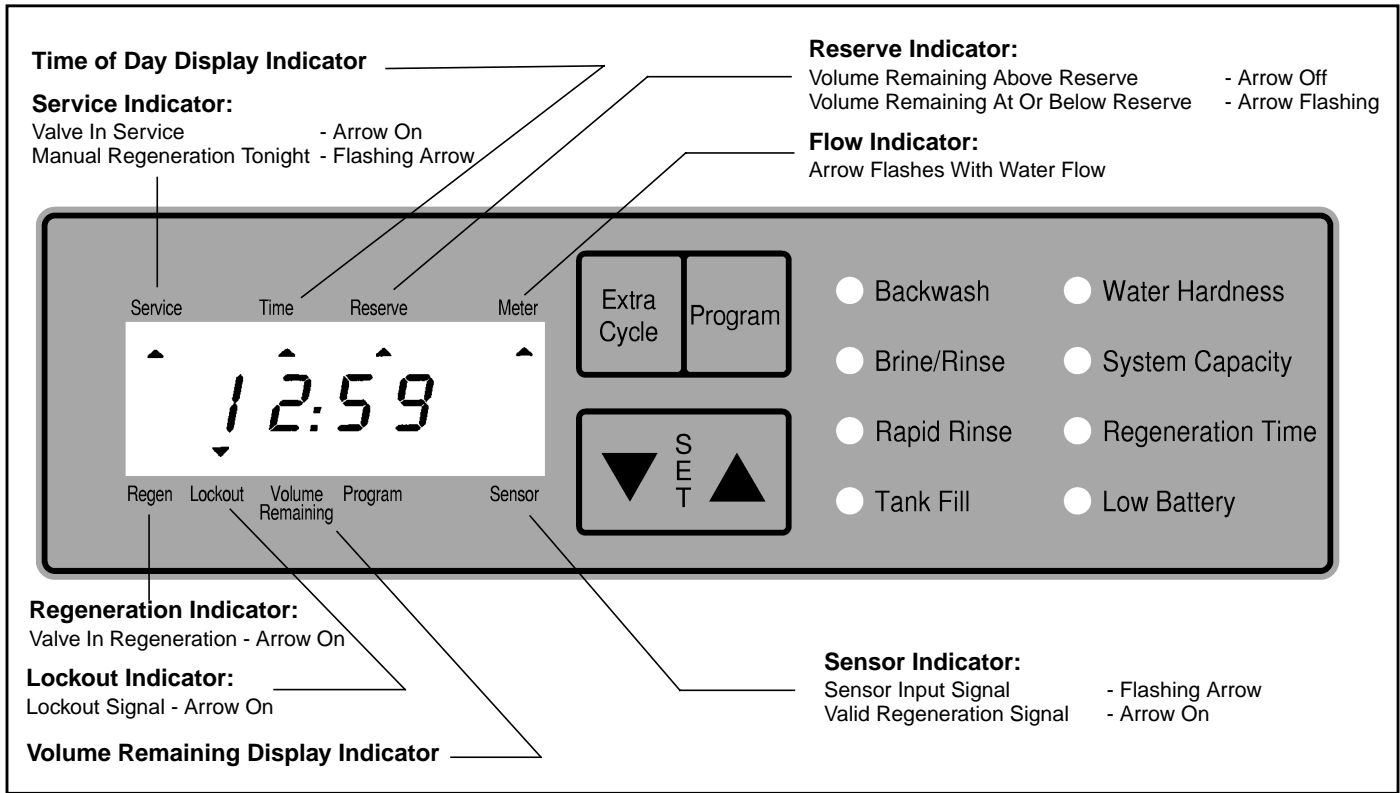

Normal Control Operation

Flow Meter Equipped Delayed Regeneration Valves

In Normal Operation the Time Of Day Display will alternate being viewed with the Volume Remaining Display. Water flow through the unit is indicated by the Meter Arrow that will flash in a direct relationship to flow rate. As treated water is used, the Volume Remaining Display will count down from a maximum value to the calculated reserve capacity. Once this occurs, the Reserve Arrow will begin to flash as an indication that reserve capacity is being used. At the preset Regeneration Time a regeneration cycle will then be initiated immediately.

For Example:

235 Gallons Of Water Remaining

(Valve in Service)
(No Water flow)
(Volume is below reserve capacity)

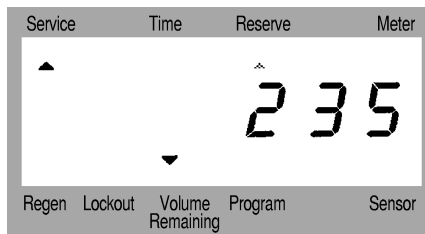

For Example:

0 Gallons Of Water Remaining

(Valve in Service)
(Water flowing, Meter Arrow flashing)
(Volume is below reserve capacity)

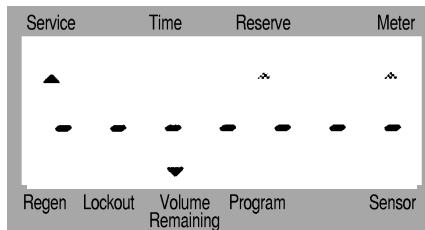

MODEL 6700 Downflow

Control Operation (Cont'd.)

Timeclock Regeneration Valves

In Normal Operation the Time Of Day Display will be viewed at all times. The control will operate normally until the days since the last regeneration reaches the preset number of days. Once this occurs, a regeneration cycle will then be initiated immediately at the preset Regeneration Time.

Flow Meter Equipped Immediate Regeneration Valves

In Normal Operation the Time Of Day Display will alternate being viewed with the Volume Remaining Display. Water flow through the unit is indicated by the Meter Arrow that will flash in a direct relationship to flow rate. As treated water is used, the Volume Remaining Display will count down from a maximum value to zero. Once this occurs a regeneration cycle will then be initiated immediately.

For Example:

525 Gallons Of Water Remaining

(Valve in Service)

(Water flowing, Meter Arrow flashing)

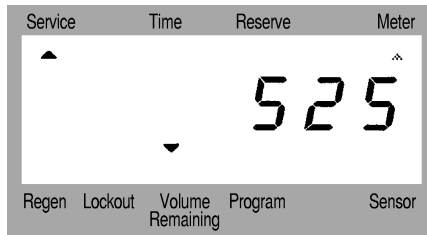

Sensor Immediate Regeneration Valves

In Normal Operation the Time Of Day Display will be viewed at all times. The control will operate normally until a valid sensor input signal is received. Once this occurs, a regeneration cycle will then be initiated immediately. The Sensor Input Arrow will flash until the signal is determined to be valid.

Sensor Delayed Regeneration Valves

In Normal Operation the Time Of Day Display will be viewed at all times. The control will operate normally until a valid sensor input signal is received. Once this occurs, a regeneration cycle will then be initiated immediately at the preset Regeneration Time. The Sensor Input Arrow will flash until the signal is determined to be valid. Then the Reserve Arrow will begin to flash as an indication that reserve capacity is being used.

For Example:

12:58 P.M. With Invalid Sensor Signal

(Valve in Service)

(Sensor Arrow flashing)



For Example:

12:59 P.M. With Invalid Sensor Signal

(Valve in Service)

(Sensor Arrow On)

(Reserve Arrow flashing) (Delayed Regen.)



Immediate Regeneration Valves With Days Between Regeneration Override Set

When the valve reaches its set Days Since Regeneration Override value a regeneration cycle will be initiated immediately. This event occurs regardless of the Volume Remaining display having reached zero.

Delayed Regeneration Valves With Days Between Regeneration Override Set

When the valve reaches its set Days Since Regeneration Override value a regeneration cycle will be initiated at the preset Regeneration Time. This event occurs regardless of the Volume Remaining display having reached the calculated reserve capacity.

MODEL 6700 Downflow

Control Operation (Cont'd.)

Control Operation During A Power Failure

During a power failure all control displays will be turned off and regeneration cycles delayed. The control will otherwise continue to operate normally until line power is restored or battery backup power is lost.

1. If battery backup power is never lost during a power outage, the control will continue to operate normally, without the loss of data, until line power is restored.
2. If battery backup power is lost during a power outage, the control will store the current Time Of Day, Volume Remaining, Regeneration Cycle Status, and various diagnostic displays. These stored displays will then be used upon line power restoration until updated ones are created. To indicate this type of failure, the control will flash the current Time Of Day Display to indicate that this display and the Volume Remaining Display may not be correct.

Control Operation During Regeneration

In regeneration the control will display what regeneration step number the valve is advancing to, or has reached, and the time remaining in that step. Once all regeneration cycle steps have been completed the valve will return to service and resume normal operation.

1. First the Regeneration Arrow turns on. Then the display below is viewed to indicate that the valve is advancing to the first regeneration cycle step.

For Example:

(Valve is advancing to
Regeneration Step #1)
(#1 flashing)

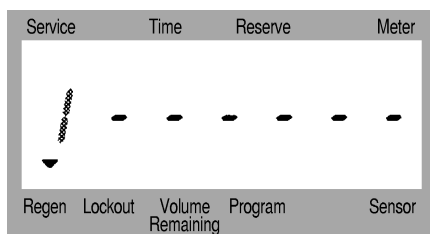

2. When the first cycle step is reached, the display becomes as shown below, A red LED will also turn on to indicate the current regeneration cycle step.

For Example:

(Regeneration Step #1 has
been reached)
(10.0 minutes remain in Step #1))

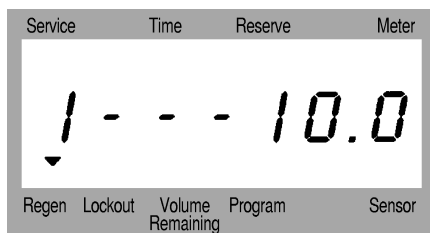

3. Pushing the Extra Cycle Button during a regeneration cycle will immediately advance the valve to the next cycle step position and resume normal step timing.
4. Pushing the Up or Down Set Button during a regeneration cycle will adjust the time remaining in a regeneration cycle step. Actual Regeneration Cycle Step programming will not be changed.

MODEL 6700 Downflow

Control Operation (Cont'd.)

Control Operation During Programming

The control will only enter the Program Mode with the valve in Service and operating on line power. While in the Program Mode the control will continue to operate normally monitoring water usage and keeping all displays up to date. Control programming is stored in memory permanently with or without line or battery backup power.

Lockout Input Operation

The Lockout Arrow will turn on whenever a Lockout Signal is being received by the control. Any requests for regeneration will be delayed until this signal is removed. Regeneration will then proceed normally.

Keypad Operation

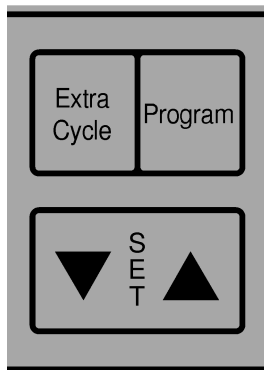

Extra Cycle Button

Pushing this button will initiate a regeneration cycle independently of actual valve conditions.

1. With immediate regeneration valves this extra regeneration would occur immediately.
2. With delayed regeneration valves this extra regeneration would occur at the set Regeneration Time. A regeneration cycle can be forced to occur immediately by pushing and holding in this button for 5 seconds.

Program Button

This button is used by the installer to program those settings indicated on the front panel by red LEDs.

Up Set Button

This button is used to set the current time of day, adjust time remaining in a regeneration cycle step, and in valve programming. The Up Arrow Button will increment a display setting.

Down Set Button

This button is used to set the current time of day, adjust time remaining in a regeneration cycle step, and in valve programming. The Down Arrow Button will decrement a display setting.

Low Battery Indicator

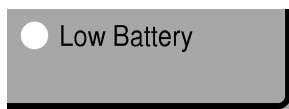

When the control is operating on line power this red LED will turn on whenever the **9V Alkaline Battery** (Not Included) used for memory backup needs to be replaced. The battery is stored inside the top cover. In the event of a power outage, the battery will maintain current operating data for approximately 24 hours at maximum battery capacity.

MODEL 6700 Downflow

Water Conditioner Flow Diagrams (Downflow Brining)

Using Black Cycle Cam (Part No. 17438)

Service Position

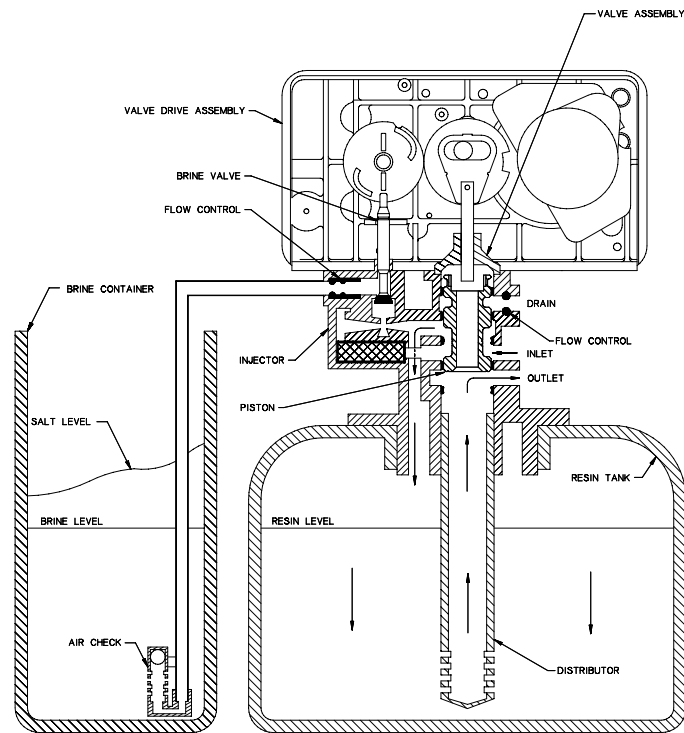

Backwash Position

(Regeneration Cycle Step #1)

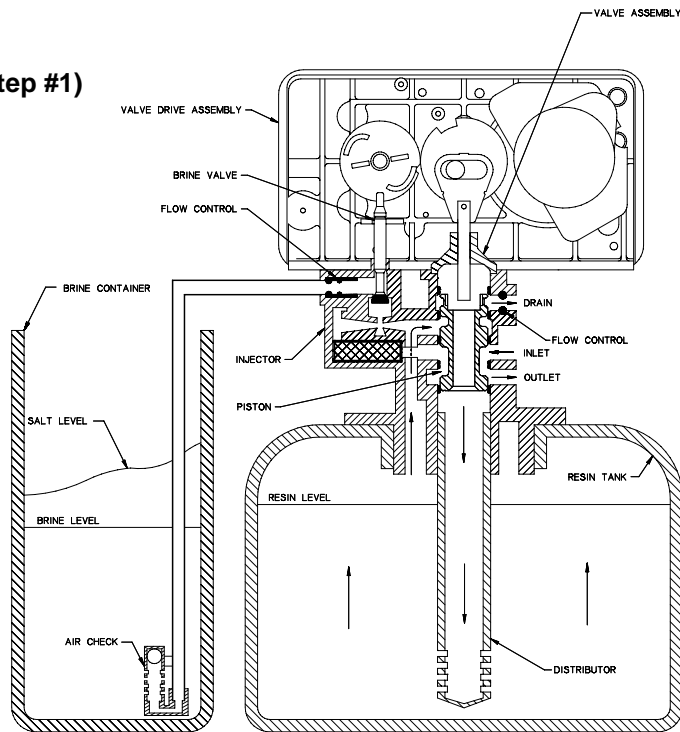

MODEL 6700 Downflow

Water Conditioner Flow Diagrams (Downflow Brining)

Using Black Cycle Cam (Part No. 17438) (Cont'd.)

Brine/Slow Rinse Position (Regeneration Cycle Step #2)

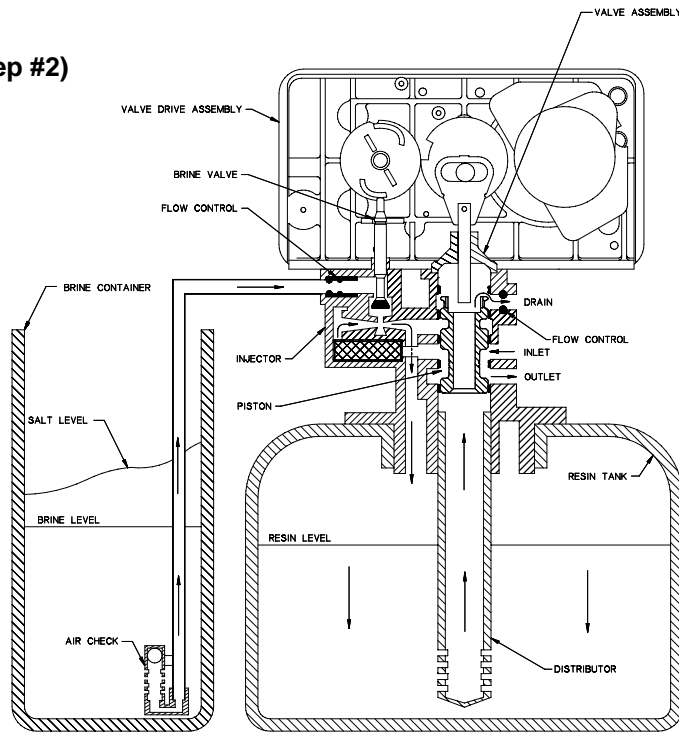

Rapid Rinse Position (Regeneration Cycle Step #3)

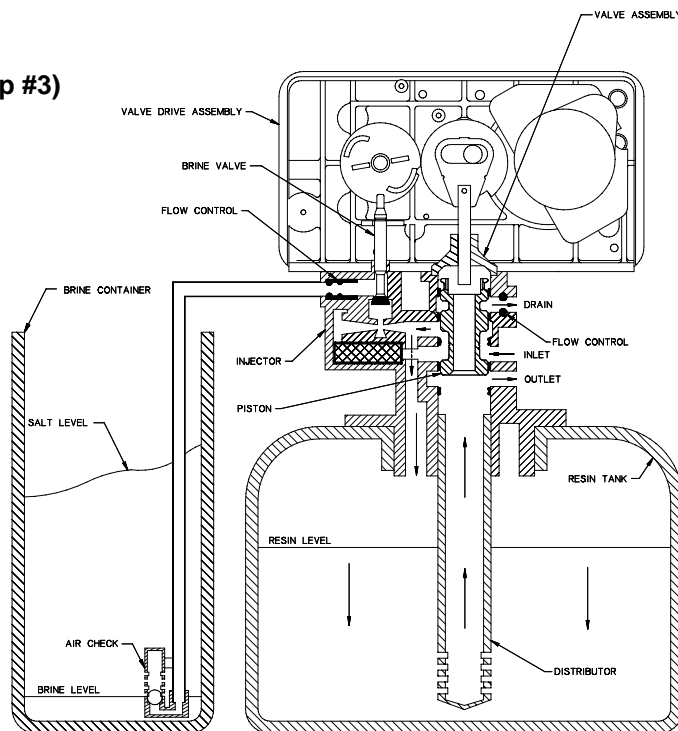

MODEL 6700 Downflow

Water Conditioner Flow Diagrams (Downflow Brining)

Using Black Cycle Cam (Part No. 17438) (Cont'd.)

Brine Tank Fill Position (Regeneration Cycle Step #4)

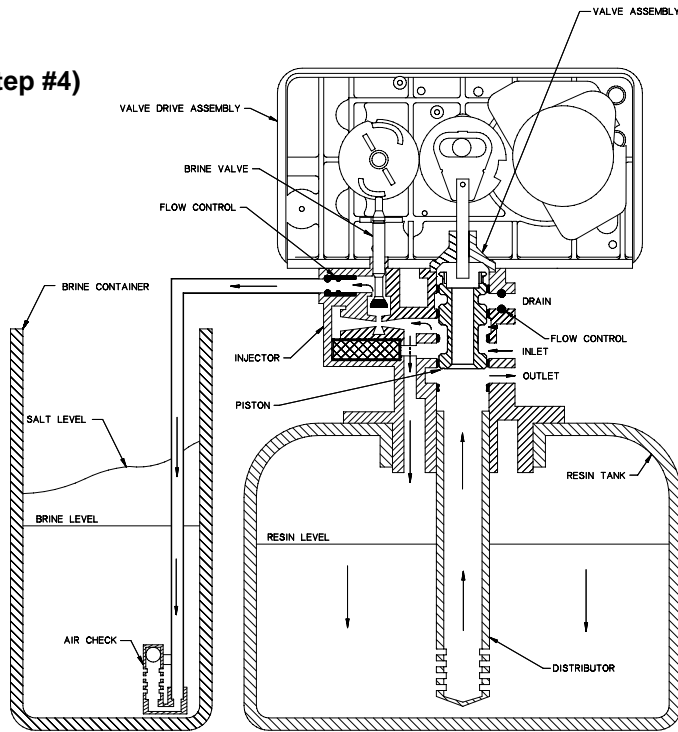

Service Position

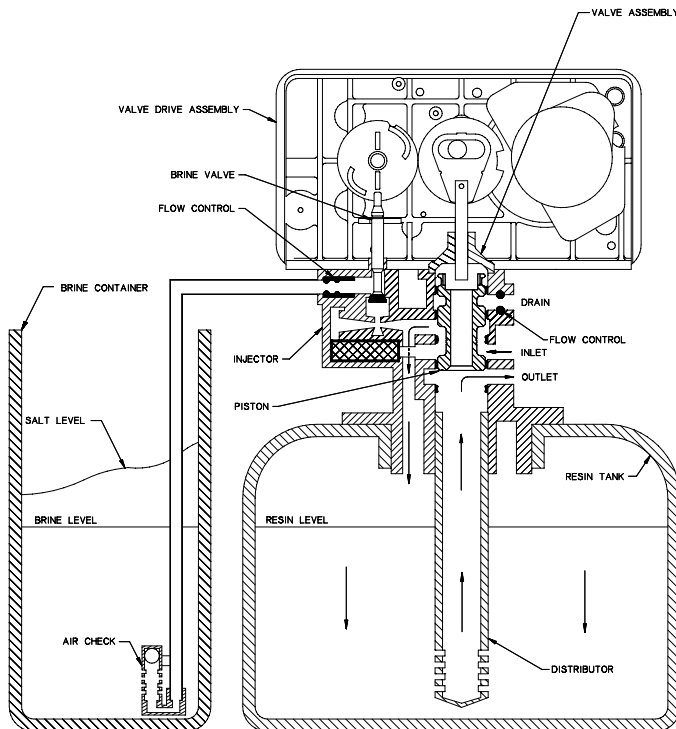

MODEL 6700 Downflow

Downflow Valve Wiring Diagram

Standard 6700 Wiring

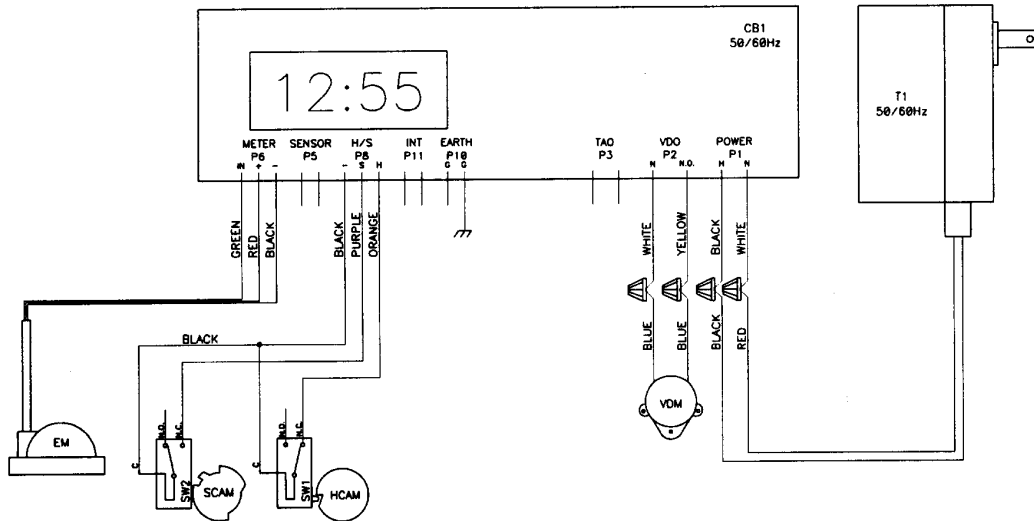

CB1 - 6600/6700 CIRCUIT BOARD
 VDM - VALVE DRIVE MOTOR
 EM - ELECTRONIC FLOW METER (OPTIONAL)
 T1 - 24V WALL TRANSFORMER

SW1 - HOMING SWITCH
 SW2 - STEP SWITCH
 HCAM - HOMING CAM
 SCAM - STEP CAM

6700 Wiring With Terminal Block Option

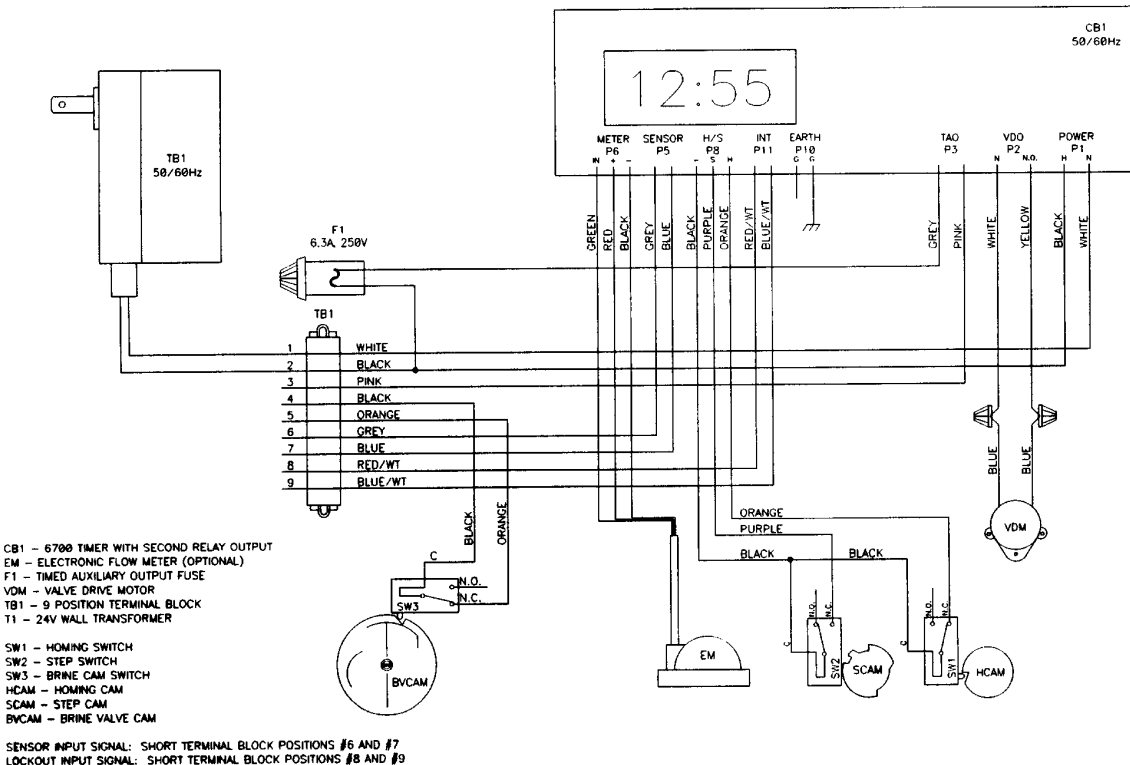

CB1 - 6700 TIMER WITH SECOND RELAY OUTPUT
 EM - ELECTRONIC FLOW METER (OPTIONAL)
 F1 - TIMED AUXILIARY OUTPUT FUSE
 VDM - VALVE DRIVE MOTOR
 TB1 - 9 POSITION TERMINAL BLOCK
 T1 - 24V WALL TRANSFORMER

SW1 - HOMING SWITCH
 SW2 - STEP SWITCH
 SW3 - BRINE CAM SWITCH
 HCAM - HOMING CAM
 SCAM - STEP CAM
 BYCAM - BRINE VALVE CAM

SENSOR INPUT SIGNAL: SHORT TERMINAL BLOCK POSITIONS #6 AND #7
 LOCKOUT INPUT SIGNAL: SHORT TERMINAL BLOCK POSITIONS #8 AND #9

MODEL 6700 Downflow

Valve Powerhead

(See opposite page for parts list)

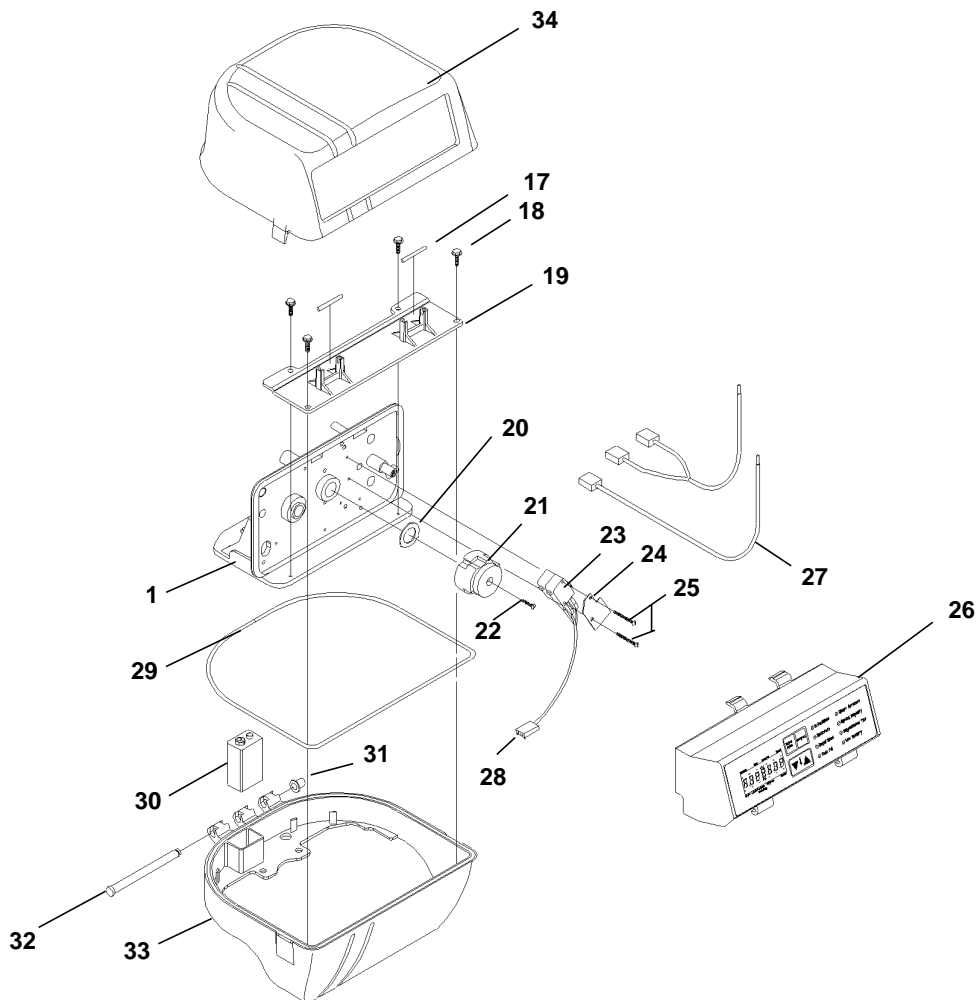
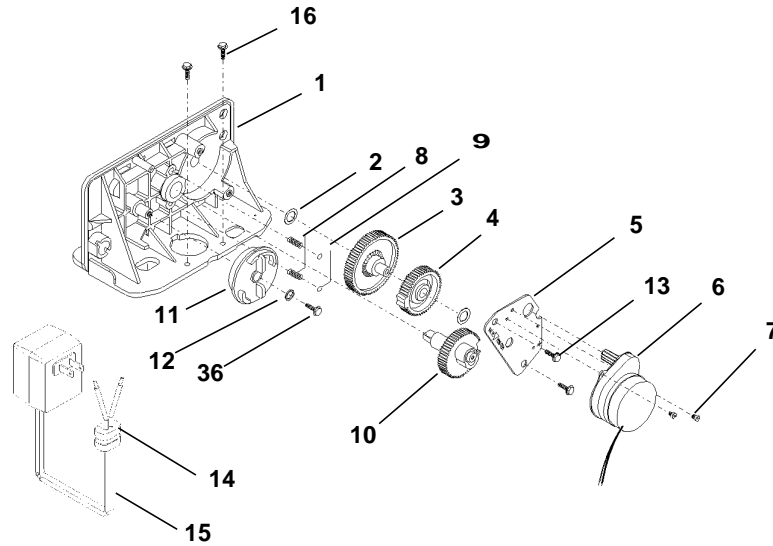

MODEL 6700 Downflow

Valve Powerhead

Parts List

Item No.	Quantity	Part No.	Description
1	1	14193-03	Drive Panel
2	1	13299	Spring Washer
3	1	13017	Idler Gear
4	1	23045	Drive Gear
5	1	13175	Motor Mounting Plate
6	1	16944	Drive Motor 2 RPM 24V 50/60 Hz
7	3	11384	Screw, Motor Mount
8	2	19080	Spring, Detent
9	2	13300	Ball, Detent
10	1	25005-10	Main Drive Gear & Shaft (Downflow Brining - Black)
11	1	18722	B/V Cam (Downflow)
12	1	12037	Washer
13	2	13296	Screw, Component
14	1	13547	Strain Relief
15	1	19674	Transformer, U.S. 24V (120V)
		25651	Transformer, European 24V (230V)
16	2	12473	Screw, Drive Mount
17	2	18754	Pin
18	4	17798	Screw, Mounting Plate
19	1	17844	Mounting Plate
20	1	19079	Friction Washer
21	1	17438	Cycle Cam (Downflow - Black)
22	1	15151	Screw, Cycle Cam
23	2	10218	Microswitch (Downflow - Black)
24	1	10302	Insulator
25	2	17876	Screw, Microswitch
26	1	19313-112	Circuit Board Housing Assembly
27	1	40042-01 & 40042-02	Wire Harness, Power - Std / with Terminal Block Option
28	1	19119-01 & 40041-02	Wire Harness, Low Voltage - Std / with Terminal Block Option
29	1	18615-01	Seal
30	1		9V Alkaline Battery (Not Included)
31	1	18679	Tapered Cap
32	1	17845	Hinge Pin
33	1	17841-xx	Bottom Cover (Specify Color)
34	1	17842-xx	Top Cover (Specify Color)
35	4	12681	Wire Nut, Beige (Not Shown)
36	1	40214	Screw

MODEL 6700 Downflow

Control Valve Assembly - Downflow Brining

(See opposite page for parts list)

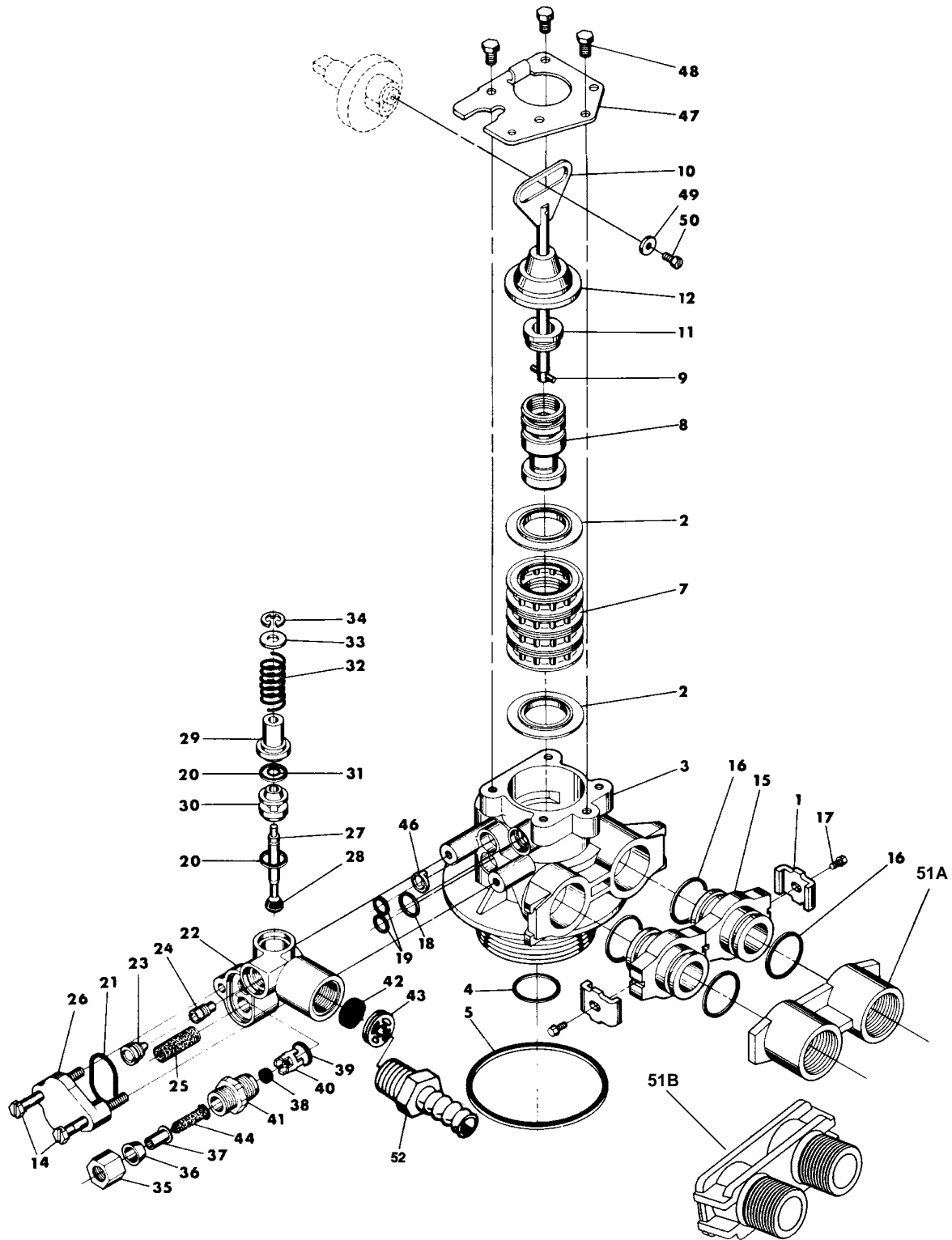

MODEL 6700 Downflow

Control Valve Assembly - Downflow Brining

Parts List

Item No.	Quantity	Part No.	Description
*1	2	13255	Adapter Clip
2	5	13242	Seal
3	1	14449	Valve Body Assembly - 1" dist.
	1	14450	Valve Body Assembly - 13/16" Dist.
4	1	13304	O-Ring - Distributor Tube - 1"
	1	10244	O-Ring - Distributor Tube - 13/16"
5	1	12281	O-Ring - Top of Tank
6			Not Assigned
7	4	14241	Spacer
8	1	17218	Piston (Used with Black Cycle Cam)
9	1	13306	Piston Pin
10	1	13001-04	Piston Rod Assembly
11	1	14309	Piston Retainer
12	1	13446-40	End Plug Assembly - Green
14	2	13315	Screw - Injector Mounting
*15	2	19228	Adapter Coupling
*16	4	13305	O-Ring - Adapter Coupling
*17	2	13314	Screw - Adapter Coupling
18	1	12638	O-Ring - Drain
19	2	13301	O-Ring - Injector
20	2	13302	O-Ring - Brine Spacer
21	1	13303	O-Ring - Injector Cover
22	1	13163	Injector Body
23	1	10913	Injector Nozzle - Specify Size
24	1	10914	Injector Throat - Specify Size
25	1	10227	Injector Screen
26	1	13166	Injector Cover
27	1	13172	Brine Valve Stem
28	1	12626	Brine Valve Seat
29	1	13165	Brine Valve Cap
30	1	13167	Brine Valve Spacer
31	1	12550	Quad Ring
32	1	11973	Spring - Brine Valve
33	1	16098	Washer - Brine Valve
34	1	11981-01	Retaining Ring
35	1	10329	B.L.F.C. Fitting Nut 3/8"
36	1	10330	B.L.F.C. Ferrule 3/8"
37	1	10332	B.L.F.C. Tube Insert 3/8"
38	1		B.L.F.C. Button - Specify Size
39	1	12977	O-Ring - B.L.F.C.
40	1	13245	B.L.F.C. Button Retainer
41	1	13244	B.L.F.C. Fitting
42	1		D.L.F.C. Button - Specify Size
43	1	13173	D.L.F.C. Button Retainer
44	1	12767	Screen - Brine Line
45	1	15348	O-Ring - D.L.F.C. (not shown)
46	1	13497	Air Dispenser
47	1	13546	End Plug Retainer
48	3	12112	Screw
49	1	13363	Washer
50	1	13296	Screw
51A	1	13708	Yoke, Brass, 3/4" NPT
	1	13398	Yoke, Brass, 1" NPT
51B	1	18706	Yoke, Plastic, 1" NPT
	1	18706-02	Yoke, Plastic, 3/4" NPT
52	1	13308	Drain Hose Barb

* Not used with meter controls.

MODEL 6700 Downflow

By-pass Valve Assembly, Brass

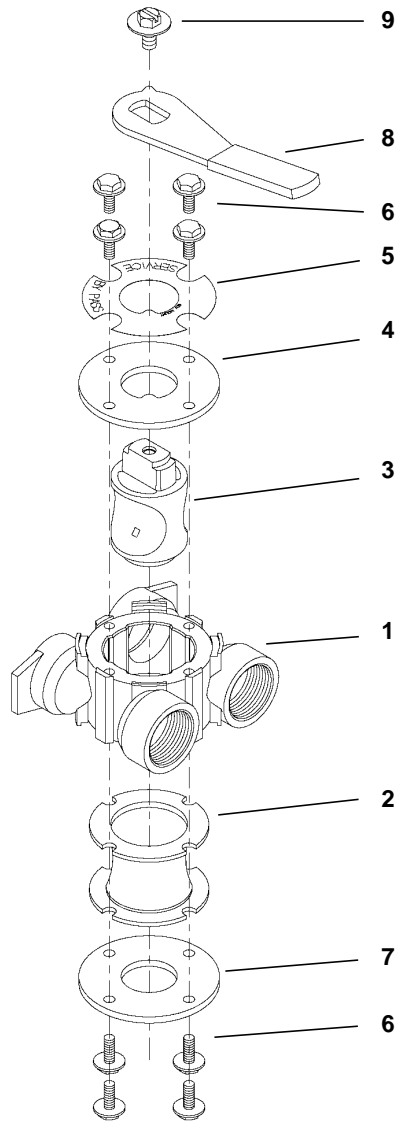

Item No.	Quantity	Part No.	Description
1	1	17290	By-Pass Valve Body, 3/4"
	1	17290NP	By-Pass Valve Body, 3/4" Nickel Plate
	1	13399	By-Pass Valve Body, 1"
	1	13399NP	By-Pass Valve Body, 1", Nickel Plate
2	1	11726	Seal, By-Pass
3	1	11972	Plug, By-Pass
4	1	11978	Side Cover
5	1	13604-01	Label
6	8	15727	Screw
7	1	11986	Side Cover
8	1	11979	Lever, By-Pass
9	1	11989	Screw, Hex Head, 1/4-14

MODEL 6700 Downflow

By-pass Valve Assembly, Plastic

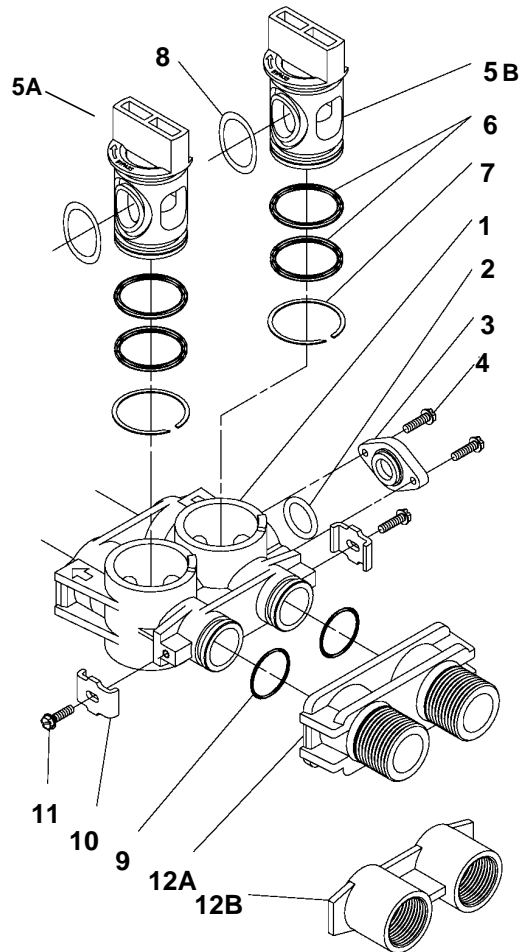

Item No.	Quantity	Part No.	Description
1	1	19723	By-Pass Valve Body, Plastic
2	1	11183	O-Ring, -015
3	1	19724	Cap, By-Pass
4	2	17512	Screw, Hex Washer Head, #6-24 x 3
5A	1	17820	Plug, By-Pass Inlet
5B	1	17820-01	Plug, By-Pass, Outlet (White)
6	4	18661	O-Ring, -218
7	2	18662	Retaining Ring
8	2	18660	O-Ring
9	2	13305	O-Ring, -119
10	2	13255	Clip, Mounting
11	2	13314	Screw, Hex Washer Head, 8-18 x 5/8
12A	1	18706	Yoke, Plastic, 1" NPT
		18706-02	Yoke, Plastic, 3/4" NPT
12B	1	13708	Yoke, Brass, 3/4" NPT
	1	13708NP	Yoke, 3/4" NPT Nickel Plated
	1	13398	Yoke, Brass, 1" NPT
	1	13398NP	Yoke, 1" NPT Nickel Plated

MODEL 6700 Downflow

Meter Assembly

(See opposite page for parts list)

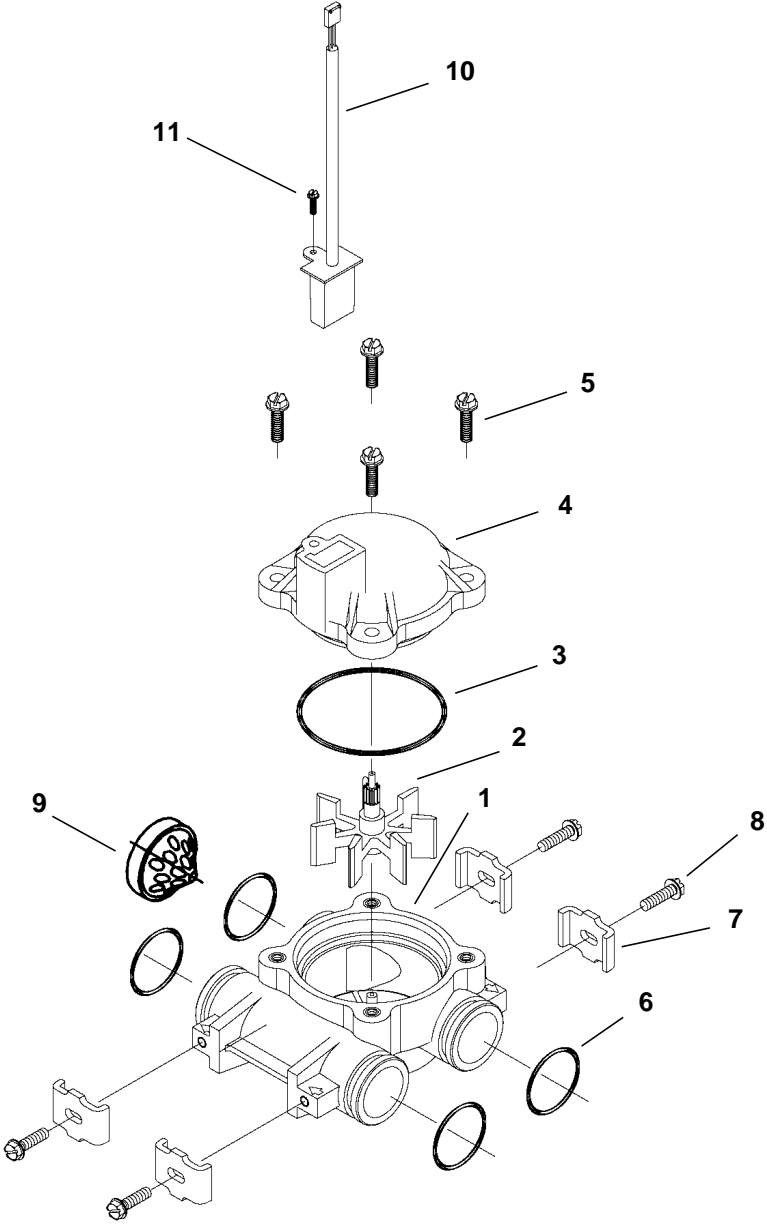

MODEL 6700 Downflow

Meter Assembly

Parts List

Item No.	Quantity	Part No.	Description
1	1	13821	Meter Body
2	1	13509	Impeller
3	1	13847	O-Ring, -137
4	1	14716	Meter Cap Assembly, Electronic
5	4	12473	Screw, Hex Washer, 10-24 x 5/8
6	4	13305	O-Ring, -119
7	4	13255	Clip, Mounting
8	4	13314	Screw, Hex Washer Head, 8-18 x 5/8
9	1	14613	Flow Straightener
10	1	19121-01	Hardness Assembly, Flow Meter
11	1	17798	Screw

MODEL 6700 Downflow

2310 Safety Brine Valve

(See Opposite Page for Part List)

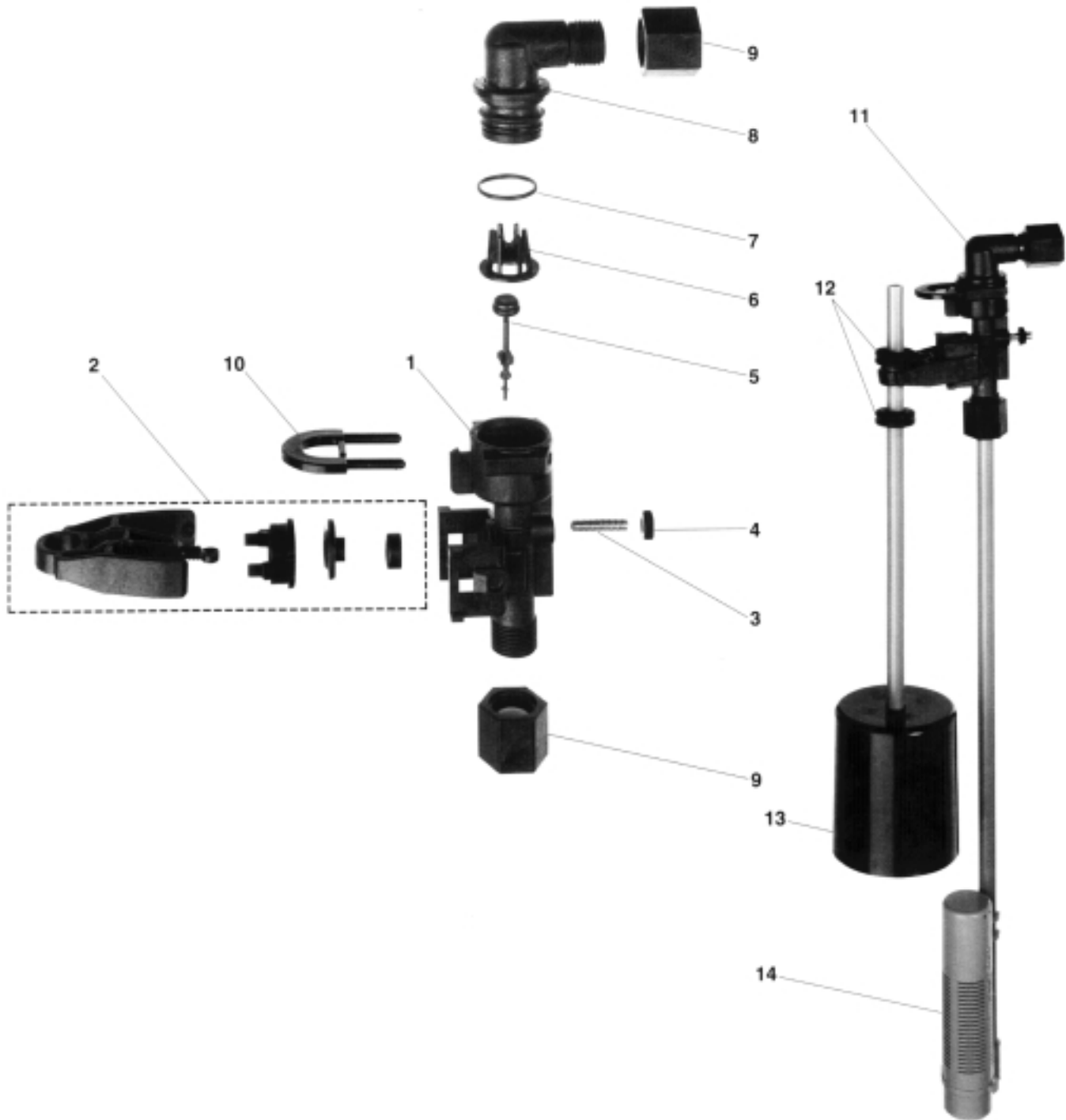

MODEL 6700 Downflow

Safety Brine Valve

Parts List

Item No.	Quantity	Part No.	Description
1.....	1	19645	Safety Brine Valve Body
2.....	1	19803	Safety Brine Valve Arm Assembly
3.....	1	19804	Stud, 10-24
4.....	1	19805	Nut, 10-24
5.....	1	19652-01.....	Poppet & Seal
6.....	1	19649	Flow Dispenser
7.....	1	11183	O-Ring, -017
8.....	1	19647	Elbow, Safety Brine Valve
9.....	2	19625	Nut Assembly, 3/8
10.....	1	18312	Retaining Clip
11.....	1	60014	Safety Brine Valve, 2310 (includes items 1-10)
12.....	2	10150	Grommet (included with item 13)
13.....	1	60068	Float Assembly, 2310
14.....	1	60002	500 Air Check Assembly

MODEL 6700 Downflow

2300 Safety Brine Valve

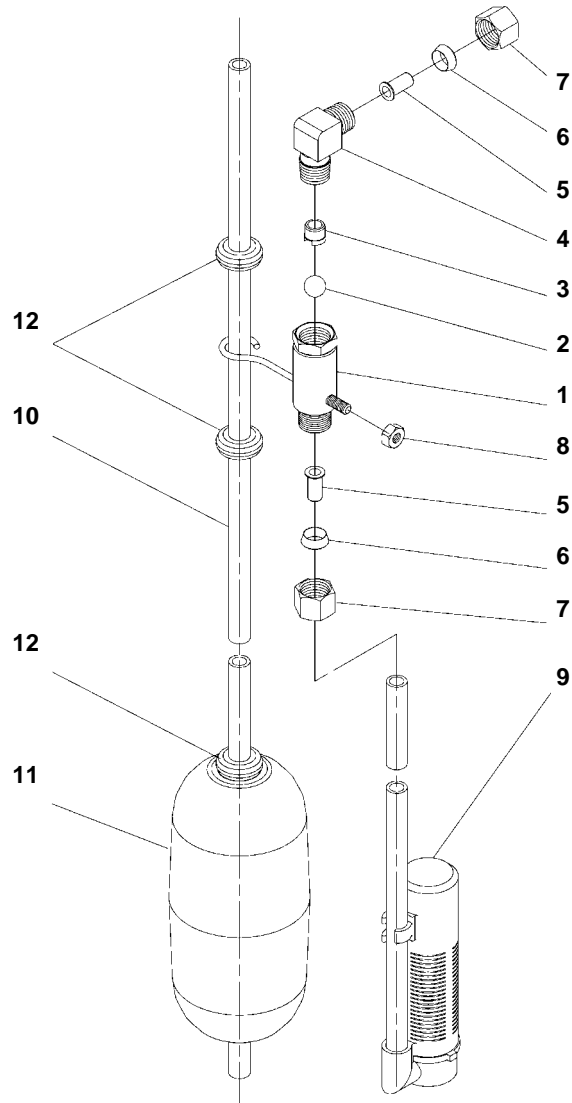

Item No.	Quantity	Part No.	Description
1	1	60027-00	2300 Safety Brine Valve body
2	1	10138	Ball, 3/8"
3	1	11566	Bull Stop
4	1	10328	Elbow, 1/4 x 1/4 T
5	2	10332	Insert, 3/8
6	2	10330	Sleeve, 3/8
7	2	10329	Tube Nut, 3/8
8	1	10186	Nut, Hex, 10-32, Nylon
9	1	60002	#500 Air Check
10	1	10149	Float Rod, 30"
11	1	10700	Float Assembly, Blue/White
12	4	10150	Grommet

MODEL 6700 Downflow

Service Instructions

A. TO REPLACE TIME BRINE VALVE, INJECTORS, AND SCREEN

1. Turn off water supply to conditioner:
 - a. If the conditioner installation has a "three valve" by-pass system, first open the valve in the by-pass line, then close the valves at the conditioner inlet and outlet.
 - b. If the conditioner has an integral by-pass valve, put it in the by-pass position.
 - c. If there is only a shut-off valve near the conditioner inlet, close it.
2. Relieve water pressure in the conditioner by stepping the control into the backwash position momentarily. Return the control to the service position.
3. Unplug electrical cord from outlet.
4. Disconnect brine tube and drain line connections at the injector body.
5. Remove the two injector body mounting screws. The injector and brine module can now be removed from the control valve. Remove and discard brine body O-rings.
- 6A. To replace brine valve.
 1. Pull brine valve from injector body, also remove and discard O-ring at bottom of brine valve hole.
 2. Apply silicone lubricant to new O-ring and reinstall at bottom of brine valve hole.
 3. Apply silicone lubricant to O-ring on new valve assembly and press into brine valve hole, shoulder on bushing should be flush with injector body.
- 6B. To replace injectors and screen.
 1. Remove injector cap and screen, discard O-ring. Unscrew injector nozzle and throat from injector body.
 2. Screw in new injector throat and nozzle, be sure they are sealed tightly. Install a new screen.
 3. Apply silicone lubricant to new O-ring and install around oval extension on injector cap.
7. Apply silicone lubricant to three new O-rings and install over three bosses on injector body.
8. Insert screws with washers thru injector cap and injector. Place this assembly thru hole in timer housing and into mating holes in the valve body. Tighten screws.
9. Reconnect brine tube and drain line.
10. Return by-pass or inlet valving to normal service position. Water pressure should now be applied

to the conditioner, and any by-pass line shut off.

11. Check for leaks at all seal areas. Check drain seal with the control in the backwash position.
12. Plug electrical cord into outlet.
13. Set time of day and cycle the control valve manually to assure proper function. Make sure control valve is returned to the service position.
14. Make sure there is enough salt in the brine tank.
15. Start regeneration cycle manually if water is hard.

B. TO REPLACE TIMER

1. Follow Steps A.1 through A.3.
2. Remove the control valve back cover. Remove the control valve front cover. Disconnect the meter dome signal wire from the front cover and feed it back through the control.
3. Remove screw and washer at drive yoke. Remove timer mounting screws. The entire timer assembly will now lift off easily.
4. Put new timer on top of valve. Be sure drive pin on main gear engages slot in drive yoke.
5. Replace timer mounting screws. Replace screw and washer at drive yoke. Replace meter signal wire.
6. Return by-pass or inlet valving to normal service position. Water pressure should now be applied to the conditioner, and any by-pass line shut off.
7. Replace the control valve back cover.
8. Follow Steps A.12 through A.15.

C. TO REPLACE PISTON ASSEMBLY

1. Follow Steps A.1 through A.3.
2. Remove the control valve back cover. Remove the control valve front cover. Disconnect the meter dome signal wire from the front cover and feed it back through the control.
3. Remove screw and washer at drive yoke. Remove timer mounting screws. The entire timer assembly will now lift off easily. Remove end plug retainer plate.
4. Pull upward on end of piston yoke until assembly is out of valve.
5. Inspect the inside of the valve to make sure that all spacers and seals are in place, and that there is no foreign matter that would interfere with the valve operation.
6. Take new piston assembly as furnished and push piston into valve by means of the end plug. Twist yoke carefully in a clockwise direction to properly align it with drive gear. Replace end plug retainer plate.

MODEL 6700 Downflow

Service Instructions (Cont'd.)

7. Place timer on top of valve. Be sure drive pin on main gear engages slot in drive yoke.
8. Replace timer mounting screws. Replace screw and washer at drive yoke.
9. Return by-pass or inlet to normal service position. Water pressure should now be applied to the conditioner, and any by-pass line shut off.
10. Replace the control valve back cover.
11. Follow Steps A.12 through A.15.

D. TO REPLACE SEALS AND SPACERS

1. Follow Steps A.1 through A.3.
2. Remove the control valve back cover. Remove the control valve front cover. Disconnect the meter dome signal wire from the front cover and feed it back through the control.
3. Remove screw and washer at drive yoke. Remove timer mounting screws. The entire timer assembly will now lift off easily. Remove end plug retainer plate.
4. Pull upward on end of piston rod yoke until assembly is out of valve. Remove and replace seals and spacers.
5. Take piston assembly and push piston into valve by means of the end plug. Twist yoke carefully in a clockwise direction to properly align it with drive gear. Replace end plug retainer plate.
6. Place timer on top of valve. Be sure drive pin on main gear engages slot in drive yoke.
7. Replace timer mounting screws. Replace screw and washer at drive yoke.
8. Return by-pass or inlet valving to normal service position. Water pressure should now be applied to the conditioner, and any by-pass line shut off.
9. Replace the control valve back cover.
10. Follow Steps A.12 through A.15.

E. TO REPLACE METER

1. Follow Steps A.1 through A.3.
2. Remove screw holding signal wire from meter dome.
3. Remove two screws and clips at by-pass valve or yoke. Pull resin tank away from plumbing connections.

4. Remove two screws and clips at control valve. Pull meter module out of control valve.
5. Apply silicone lubricant to four new O-rings and assemble to four ports on new meter module.
6. Assemble meter to control valve. Note, meter portion of module must be assembled at valve outlet.
7. Attach two clips and screws at control valve. Be sure clip legs are firmly engaged with lugs.
8. Push resin tank back to the plumbing connections and engage meter ports with by-pass valve or yoke.
9. Attach two clips and screws at by-pass valve or yoke. Be sure clip legs are firmly engaged with lugs.
10. Return by-pass or inlet valving to normal service position. Water pressure should now be applied to the conditioner, and any by-pass line shut off.
11. Check for leaks at all seal areas.
12. Connect meter dome signal wire.
13. Follow Steps A.12 through A.15.

F. TO REPLACE METER COVER AND/OR IMPELLER

1. Follow Steps A.1 through A.3.
2. Remove screw holding signal wire from meter dome.
3. Remove four screws on cover.
4. Lift cover off of meter module, discard O-ring.
5. Remove and inspect impeller for gear or spindle damage, replace if necessary.
6. Apply silicone lubricant to new O-ring and assemble to the smallest diameter on meter cover.
7. Assemble cover to meter module. Be sure impeller spindle enters freely into cover. Press firmly on cover and rotate if necessary to assist in assembly.
8. Replace four screws and tighten.
9. Return by-pass or inlet valving to normal service position. Water pressure should now be applied to the conditioners, and any by-pass shut off.
10. Check for leaks at all seal areas.
11. Connect meter dome signal wire.
12. Follow Steps A.12 through A.15.

MODEL 6700 Downflow

Service Instructions (Cont'd.)

PROBLEM	CAUSE	CORRECTION
1. Softener fails to regenerate.	<ul style="list-style-type: none"> A. Electrical service to unit has been interrupted. B. Timer is not operating properly. C. Defective valve drive motor. D. Timer programming bad (improper programming). 	<ul style="list-style-type: none"> A. Assure permanent electrical service (check fuse, plug, pull chain or switch). B. Replace timer. C. Replace drive motor. D. Check programming and reset as needed.
2. Softener delivers hard water.	<ul style="list-style-type: none"> A. By-pass valve is open. B. No salt in brine tank. C. Injectors or screen plugged. D. Insufficient water flowing into brine tank. E. Hot water tank hardness. F. Leak at distributor tube. G. Internal valve leak. H. Flow meter jammed. I. Flow meter cable disconnected or not plugged into meter cap. J. Improper programming. 	<ul style="list-style-type: none"> A. Close by-pass valve. B. Add salt to brine tank and maintain salt level above water level. C. Replace injectors and screen. D. Check brine tank fill time and clean brine line flow if plugged. E. Repeated flushings of the hot water tank is required. F. Make sure distributor tube is not cracked. Check O-ring and tube pilot. G. Replace seals and spacers and/or piston. H. Remove obstruction from flow meter. I. Check meter cable connection to timer and meter cap. J. Reprogram the control to the proper regeneration type, inlet water hardness, capacity or flow meter size.
3. Unit uses too much salt.	<ul style="list-style-type: none"> A. Improper salt setting. B. Excessive water in brine tank. C. Improper programming. 	<ul style="list-style-type: none"> A. Check salt usage and salt setting. B. See problem no. 7. C. Check programming and reset as needed.
4. Loss of water pressure.	<ul style="list-style-type: none"> A. Iron buildup in line to water conditioner. B. Iron buildup in water conditioner. C. Inlet of control plugged due to foreign material broken loose from pipes by recent work done on plumbing system. 	<ul style="list-style-type: none"> A. Clean line to water conditioner. B. Clean Control and add resin cleaner to resin bed. Increase frequency of regeneration. C. Remove piston and clean control.
5. Loss of resin through drain line.	<ul style="list-style-type: none"> A. Air in water system. B. Drain line flow control is too large. 	<ul style="list-style-type: none"> A. Assure that well system has proper air eliminator control. Check for dry well condition. B. Ensure drain line flow control is sized correctly.

MODEL 6700 Downflow

Service Instructions (Cont'd.)

PROBLEM	CAUSE	CORRECTION
6. Iron in conditioned water.	<p>A. Fouled resin bed.</p> <p>B. Iron content exceeds recommended parameters.</p>	<p>A. Check backwash, brine draw and brine tank fill. Increase frequency of regeneration. Increase backwash time.</p> <p>B. Add iron removal from filter or system.</p>
7. Excessive water in brine tank.	<p>A. Plugged drain line flow control.</p> <p>B. Brine valve failure.</p> <p>C. Improper programming.</p>	<p>A. Clean flow control.</p> <p>B. Replace brine valve.</p> <p>C. Check programming and reset as needed.</p>
8. Salt water in service line.	<p>A. Plugged injector system.</p> <p>B. Timer not operating properly.</p> <p>C. Foreign material in brine valve.</p> <p>D. Foreign material in brine line flow control.</p> <p>E. Low water pressure.</p> <p>F. Improper programming.</p>	<p>A. Clean injector and replace screen.</p> <p>B. Replace timer.</p> <p>C. Clean or replace brine valve.</p> <p>D. Clean brine line flow control.</p> <p>E. Raise water pressure.</p> <p>F. Check programming and reset as needed.</p>
9. Softener fails to draw brine.	<p>A. Drain line flow control is plugged.</p> <p>B. Injector is plugged.</p> <p>C. Injector screen plugged.</p> <p>D. Line pressure is too low.</p> <p>E. Internal control leak.</p> <p>F. Improper programming.</p> <p>G. Timer not operating properly.</p>	<p>A. Clean drain line flow control.</p> <p>B. Clean or replace injectors.</p> <p>C. Replace screen.</p> <p>D. Increase line pressure. (Line pressure must be at least 25 psi at all times.)</p> <p>E. Change seals and spacers and/or piston assembly.</p> <p>F. Check programming and reset as needed.</p> <p>G. Replace timer.</p>
10. Control cycles continuously.	<p>A. Timer not operating properly.</p> <p>B. Faulty microswitches and or harness.</p> <p>C. Faulty cycle cam operation.</p>	<p>A. Replace timer.</p> <p>B. Replace faulty microswitch or harness.</p> <p>C. Replace cycle cam or reinstall.</p>
11. Drain flows continuously.	<p>A. Foreign material in control.</p> <p>B. Internal control leak.</p> <p>C. Control valve jammed in brine or backwash position.</p> <p>D. Timer motor stopped or jammed.</p> <p>E. Timer not operating properly.</p> <p>F. Faulty cycle cam operation.</p> <p>G. Faulty microswitches and/or harness.</p>	<p>A. Remove Piston assembly and inspect bore, remove foreign material & check control in various regeneration positions.</p> <p>B. Replace seals and/or piston assembly.</p> <p>C. Replace piston and seals and spacers.</p> <p>D. Replace timer, motor and check all gears for missing teeth.</p> <p>E. Replace timer.</p> <p>F. Replace cycle cam or reinstall.</p> <p>G. Replace faulty microswitches and/or harness.</p>

MODEL 6700 Downflow

Service Assemblies

- 60022-25 ... BLFC .25 GPM**
60022-50 ... BLFC .50 GPM
60022-100 ... BLFC 1.0 GPM
For Illustration, See Page 16
12094..... Flow Washer .25 GPM
12095..... Flow Washer .50 GPM
12097..... Flow Washer 1.0 GPM
1..... 12977..... O-Ring, -015
1..... 13244..... Adapter, BLFC
1..... 13245..... Retainer, BLFC
60032..... Brine Valve
For Illustration, See Page 16
1..... 11973..... Spring, Brine Valve
1..... 11981-01 ... Retaining Ring
1..... 12550..... Quad Ring, -009
1..... 13165..... Cap, Brine Valve
1..... 13167..... Spacer, Brine Valve
2..... 13302..... O-Ring, -014
1..... 16098..... Washer, Plain, Nylon
1..... 13172..... Brine Valve Stem
1..... 12626
60040..... By Pass, 3/4", Brass
60040NP ... By Pass, 3/4", Nickel
60041..... By Pass, 1", Brass
60041NP ... By Pass, 1", Nickel
For Illustration and Parts List,
See Page 18
60049..... Bypass, Plastic 3/4"
For Illustration, and Parts List,
See Page 19
**60102-71 ... 6700 Piston Assembly –
Downflow**
For Illustration, See Page 16
1..... 13001-04 ... Piston Rod Assembly
1..... 14309..... Piston Rod Retainer
1..... 13446-40 ... End Plug Assembly, Green
1..... 17218..... Piston, Downflow Rapid Rinse
60125..... 6700 Seal and Spacer Kit
For Illustration and Parts List,
See Pages 16 and 17
5..... 13242..... Seal
4..... 14241..... Spacer
60084-..... Injector Drain Module Assembly
(Specify Inj. Number, D.L.F.C. Size,
B.L.F.C. Size)
For Illustration and Parts List,
See Pages 16 and 17 for Part No.'s
18-44.
60086-50 ... 6700 Meter Assembly
For Illustration and Parts List,
See Page 20
**19313-..... Assembly, Circuit Board
Housing, 1 Relay**
-112 24V B/W Brine Rinse,
Black
**60343-..... (Specify Voltage) 6700 Metered
Power Head Assembly**
Downflow, B/W Brine Rinse,
less Cover
-1122 24V 50/60HZ,
Black, 1 Relay
**60344-..... (Specify Voltage) 6700 Time
Clock Power Head Assembly**
Downflow, B/W Brine Rinse,
less Cover
-1122 24V 50/60HZ,
Black, 1 Relay

NOTES

NOTES
